

Hinges

Zinc Die Casting, Detachable

SPECIFICATION

Types

- Type **R**: fixed bearing (pin) right
- Type **L**: fixed bearing (pin) left

Zinc die casting

Powder coated

Black, RAL 9005, textured finish **SW**

Silver, RAL 9006, textured finish **SR**

Washer

Plastic



INFORMATION

Hinges GN 161.2 are a variant with highly attractive design. The fixing screws are invisible.

During the load tests, the hinges were gradually loaded and relieved at room temperature with incrementally increasing force. For the specified values, an insignificant permanent deformation remained after relieving the load which had no effect on the function and appearance. In most cases, the failure loads are multiples of the specified value.

The details relating to the load bearing capacity are non-binding recommended values and rule out any liability. They constitute no general warranty of quality and condition. The user must determine from case to case whether a product is suitable for the intended use. Environmental influences and aging may influence these values.

TECHNICAL INFORMATION

- List of hinges types (see page 1362)

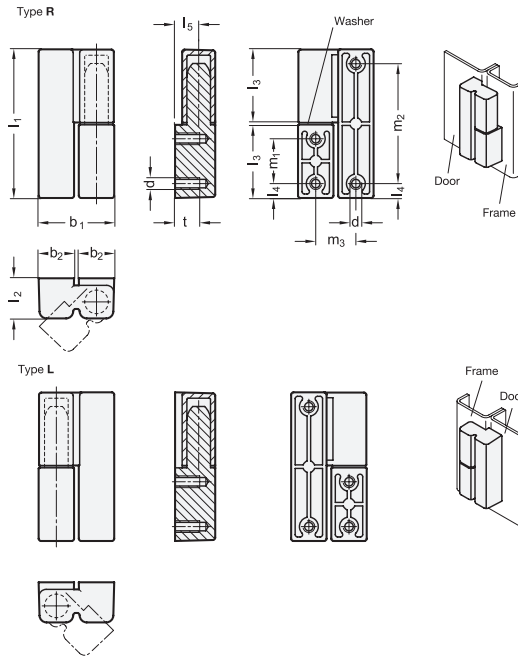

GN 161.2

Description	b1	l1	b2	d	l2	l3	l4	l5	m1	m2	m3	t	Radial load in N	Axial load in N	
GN 161.2-32-63-R-SR	32	63	15	M 5	17	31	6.1	10	19	50.8	17	10	700	2000	125
GN 161.2-32-63-R-SW	32	63	15	M 5	17	31	6.1	10	19	50.8	17	10	700	2000	125
GN 161.2-32-63-L-SR	32	63	15	M 5	17	31	6.1	10	19	50.8	17	10	700	2000	125
GN 161.2-32-63-L-SW	32	63	15	M 5	17	31	6.1	10	19	50.8	17	10	700	2000	124

